



DEEP CYCLE AGM TECHNOLOGY

HPC225-6 BCI GROUP GC2

FEATURES & BENEFITS

- True deep cycle AGM technology-GREEN SOLUTION
- Over 99.99% virgin lead for grid plate and active material
- Heavy duty grid/paste design for deep cycle application
- Maintenance free, non-spillable, valve-regulated
- Double separator configuration: long cycle life & High energy density and super anti-vibration design
- Low self-discharge for longer shelf life



ELECTRICAL SPECIFICATIONS

Voltage(V)	Capacity (AH)					Reserve Capacity (Min)		
	100HR	20HR	10HR	5HR	3HR	@25A	@56A	@75A
6	246	224	210	192	173	490	188	135

PHYSICAL SPECIFICATIONS

Model	Dimensions (mm/inches)				Weight (kg/lbs)	Terminal Type (Standard)	Case Material
	Length	Width	Height	Total Height			
HDC6-224	260 (10.24)	180 (7.09)	247 (9.72)	253 (9.96)	30.5 (67.3)	T11	ABS

Operating Temperature Range		
Discharge	Charge	Storage
-15°C~50°C(5°F~122°F)	0°C~40°C(32°F~104°F)	-15°C~40°C(5°F~104°F)

HPC225-6

DIMENSIONS

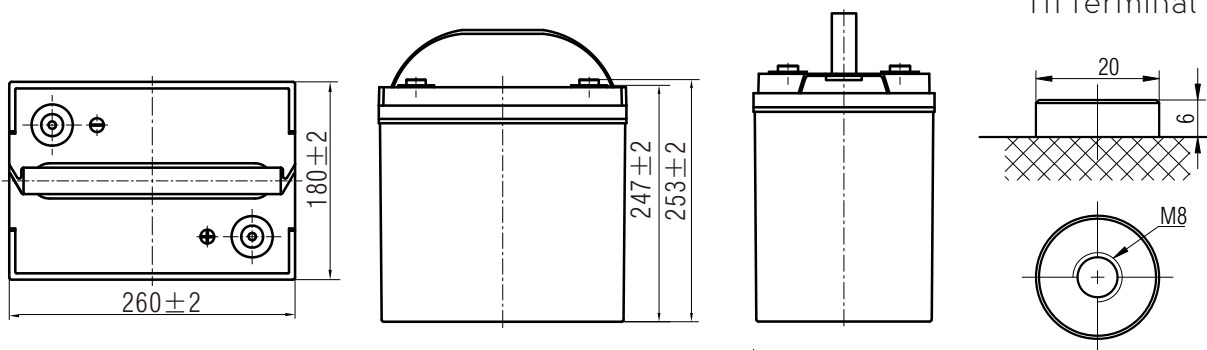

Note: Terminal Torque Values in -lb(Nm) : 97.28-130.0(11-14.7)

PERFORMANCE CHARACTERISTICS

LEOCH LDC AGM Charging Profile

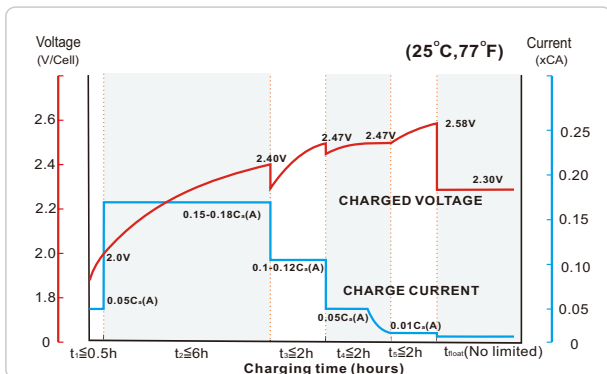

Relationship of OCV and State Of Charge ($25^{\circ}\text{C}, 77^{\circ}\text{F}$)

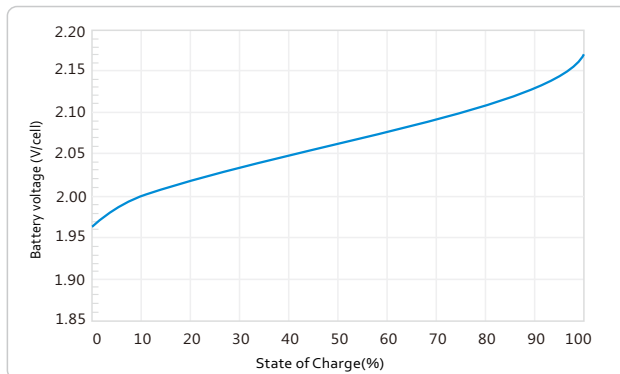

Cycle life in relation to Depth Of Discharge

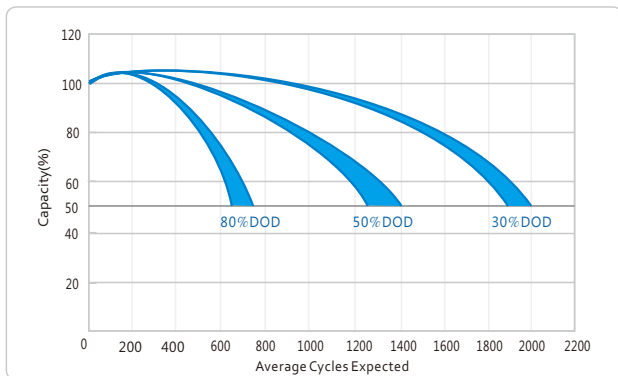

Self-discharge Characteristic

