

Lucas Traction AGM

LU220AGM

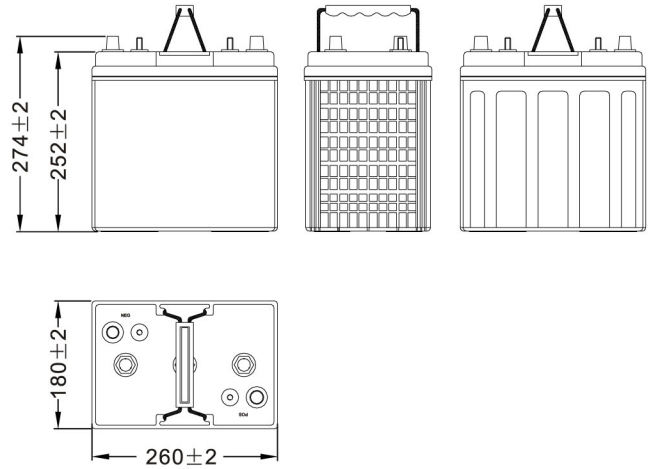

Dimensions (mm)



Physical Specification (mm)

Nominal Voltage		6V
Nominal Capacity(20HR)		213Ah
Nominal Capacity(5HR)		185Ah
Dimension	Length	260 ± 2mm(10.24inches)
	Width	180 ± 2mm(7.09inches)
	Container Height	252 ± 2mm(9.92inches)
	Total Height(with Terminal)	274 ± 2mm(10.79inches)
Dry Weight		/
Wet Weight		Approx 30.0Kg(66.1lbs)
Acid		1.310 ± 0.015g/cm ³ (25°C)
Standard Terminal		AM
Hold-Down		/
Cell plate qty		/
Case		Black-Material
Cover		Black-Material
Handle		Black-Material

Electrical Specification

Rated Capacity	20 hour rate(10.65A)	213Ah
	5 hour rate(37A)	185Ah
Reserve Capacity	25Amps	475min
Reserve Capacity	75Amps	124min

Standard Terminal (mm)

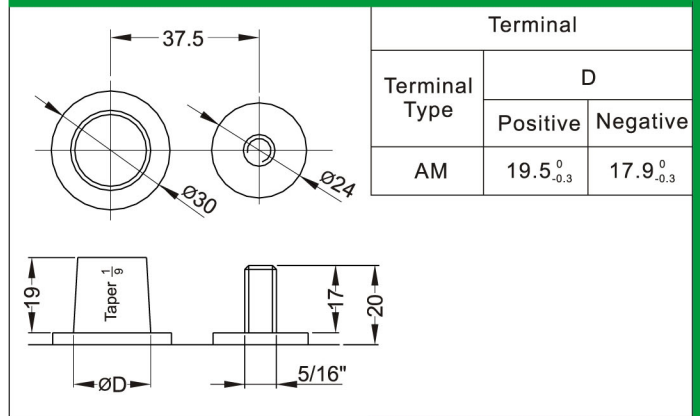

Discharge Characteristics (25 Deg C)

